



***ELIMINATING
LIVE WORK***



TODS Tribo Oil Dock System

Elimination of Live Work Solutions

A dedicated, advanced station for tribological oil sampling, enhancing the precision and ease of maintenance operations.





This unit eliminates live and manual oil sampling, removing the employees from hazards and to deliver a complete contamination free SoS sample.

Oil Sampling: a proactive maintenance practice that increases reliability, ensures compliance with industry standards, provides much needed information to help optimise lubrication, all of which can assist in extending equipment life, all while helping to reduce costs and protect the environment.

Proper oil sampling is the key for an effective oil analysis program.

Not being able to capture accurate oil samples can lead to avoidable machinery failures and unplanned downtime. Currently, maintenance personnel are required to manually perform live sampling, which puts the worker in harms away and allows the possibility for the sample to be taken incorrectly. Maximizing data density and minimizing data disturbance are crucial goals.

A Comparison

Many oil sampling systems are available on the market, the main five are:

- Oil Udder (Remote live sampling)
- ALRS Caretaker - Automatic Live Remote Sampling
- FMA (Off-Line Sampling Unit)
- Fluid Transfer Management (Manual Sampling System)
- Smart Oil M series (Automated Sampling System)

All of these sampling methods use either solenoids, valves , vacuum pumps , hoses or the operator has to be within the footprint of the machine to extract the sample.

- Static oil remains in the line until the sample is ready to be taken; a purge cycle is required every time → **waste of oil.**
- Oil flows through the solenoid into the chamber to be sampled; the solenoids would have residual oil as there is no flushing of the valve → **possible cross contamination.**
- Use of vacuum pump → **added accessory.**
- Some SoS ports have very little flow → **time loss.**
- Use of hoses and vacuum pumps → **possible cross contamination.**
- The maintainer must be in the footprint of a live machine → **safety issue.**

Why Install TODS

- The personnel is safely away and outside the footprint of the machine → **LIVE WORK ELIMINATED.**
- The sample is live and can be left in the machine fore the entire shift → **TRUE REPRESENTATION OF THE SAMPLE.**
- No hoses or fittings → **SIMPLICITY OF DESIGN, NO CROSS CONTAMINATION.**
- The unit is rugged and corrosion resistant → **NO CROSS CONTAMINATION.**
- No stagnant or old oil trapped; fresh oil is always circulating through the unit → **LIVE OIL SAMPLE EVERY TIME.**
- Universal unit mount → **CAN BE FITTED TO ANY NUMBER OF SOS POINTS ON ANY MACHINE OR PLANT.**
- Minimal fluid is spilled or wasted; minimal loss of lubricant/coolant from machine circuit → **SIGNIFICANT REDUCED ENVIRONMENTAL IMPACT.**
- **1, 2, 3 , 4 or 5 STATIONS ARE AVAILABLE.**
- Units can be grouped in modules if required.
- Same unit can do coolant as well but it will require a different cap.
- Multiple threads for various sample bottles. *(sample bottles are not supplied)*
- OEM engraving and part numbers available.
- Colour coded caps.



How It Works

The system offers flexibility to function with or without the protective bottle cap however, we highly recommend to install it. This will prevent possible damage to the bottle, sample and machine during operation hours.

Usually the bottle is installed at the beginning of the shift.

It remains in position throughout the full shift. Oil flows continually from the compartment through the bottle giving a true reading of the oil.

At the end of the shift (or when required) the protective cap is unscrewed and the sample is ready.

A new bottle is then installed.

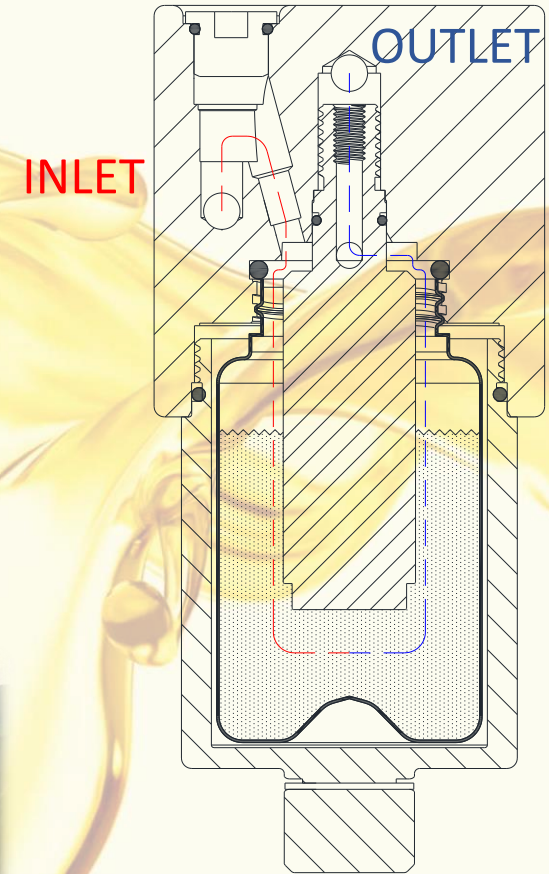

Dimensions

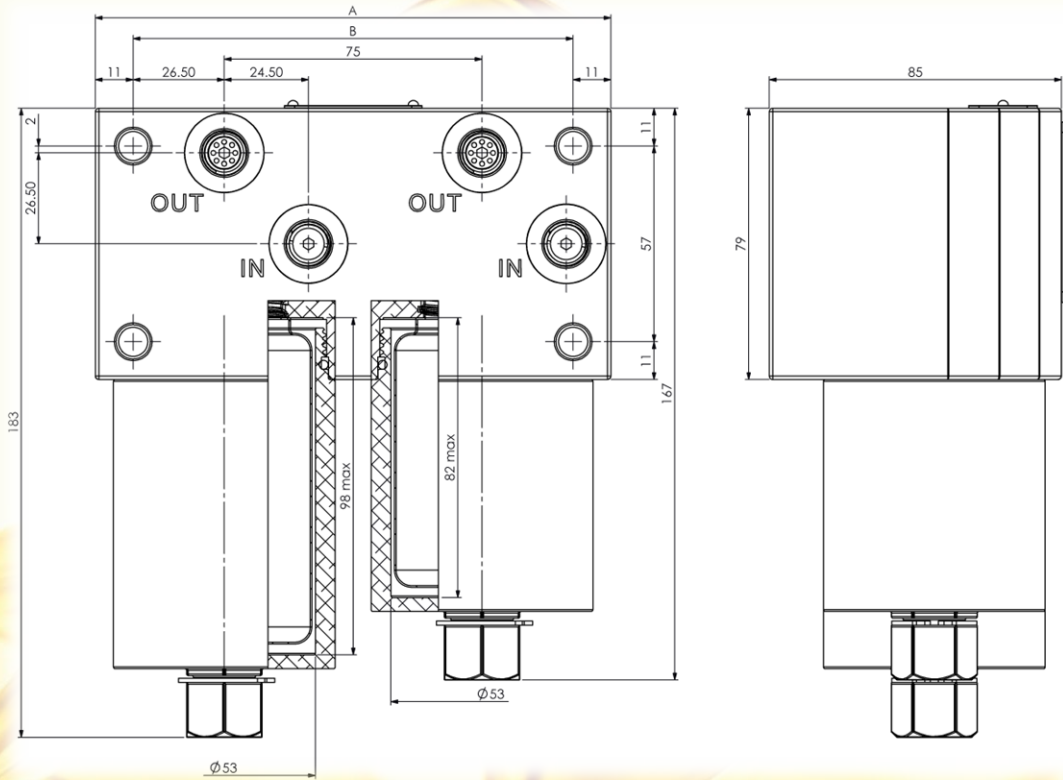

STATIONS N°	A [mm]	B [mm]	Inlet	Outlet
1	75	53	1/4" BSPP	1/4" BSPP
2	150	128	1/4" BSPP	1/4" BSPP
3	225	203	1/4" BSPP	1/4" BSPP
4	300	278	1/4" BSPP	1/4" BSPP
5	375	353	1/4" BSPP	1/4" BSPP

Unit available in 1, 2, 3, 4 and 5 stations

Customisable company name tag

Customisable product name tag

Aluminium housing with 1/4" BSPP inlet and outlet

Oil displacement spigot

Commonly used sample bottle
- not supplied with the unit

Protective aluminium caps over the sample bottle
- purchased separately
- available in different colors
- lanyard included

Technical Data

MAXIMUM OPERATING PRESSURE	1,000 psi. Pressure tested to 1,500 psi
Fluid Fill Pressure	5 psi to 150 psi desirable
Operating Temperature	0 to 80°C
Fluid Viscosity	Variable
Main Body Material	Aluminium
Fluid Types	Mineral, Synthetics and Coolant
Fluid Flow Rate	Factory Set at 1LPM SAE 30W oil @ 80Degrees (flow rate varies due to external factors)
Container fill time	100 ml/min approximate, influenced by viscosity
Sample Container Fill Volume	Directly Related to the container attached
Sample Container Compatibility	Almost All – nil found to not be compatible yet
Connection - Lines	1/4 BSPP inlet, 1/4" BSPP outlet
Branding	Customised branding optional at cost
Cap Colours	Different colours are available, refer to CAPS TABLE
Orifice supplied	1mm fitted, 1.5 and 0.6 supplied with the unit











Ordering Codes

1 station:	TODS 1
2 stations:	TODS 2
3 stations:	TODS 3
4 stations:	TODS 4
5 stations:	TODS 5

Note:

1. No bottles are supplied;
2. 1mm orifice plug is installed as default. 1.5mm and 0.6mm are supplied with the unit;
3. Products engraving to specified on purchase order or the product tags will be supplied blank;
4. If the products require personalized branding, to be specified on purchase order or standard branding will be applied;
5. **Caps are purchased separately;**
6. Caps are supplied with a lanyard.

CAPS:

GREEN	TODS-CGN	
BLUE	TODS-CBL	
PURPLE	TODS-CPR	
GREY	TODS-CGY	
TEAL	TODS-CTL	
ORANGE	TODS-COR	
CLEAR	TODS-CCL	
YELLOW	TODS-CYL	
BROWN	TODS-CBR	
RED	TODS-CRD	
HOT PINK	TODS-CPK	
GOLD	TODS-CGD	
LIGHT BLUE	TODS-CLB	

Installation Guide

The unit can be installed in almost any location that is clear and easily accessible.

It is a good practice to mount the unit as close as possible to servicing items, such as evacuation lines, any fluid related components or filters.

This unit **DOESN'T REQUIRED** any power supply; doesn't have any switches or solenoids that can fail causing downtime and unexpected cost.

The sample doesn't have to be taken at idle speed, **IT IS A LIVE SAMPLE**; it only requires a positive fluid flow.

The maintenance personnel can take a clean realistic fluid sample directly from the source/component while standing outside the footprint of the machine.

Recommended units installation: return line.

The unit can also be used for **CHECKING STORED FLUID** on service trucks or storage facilities.

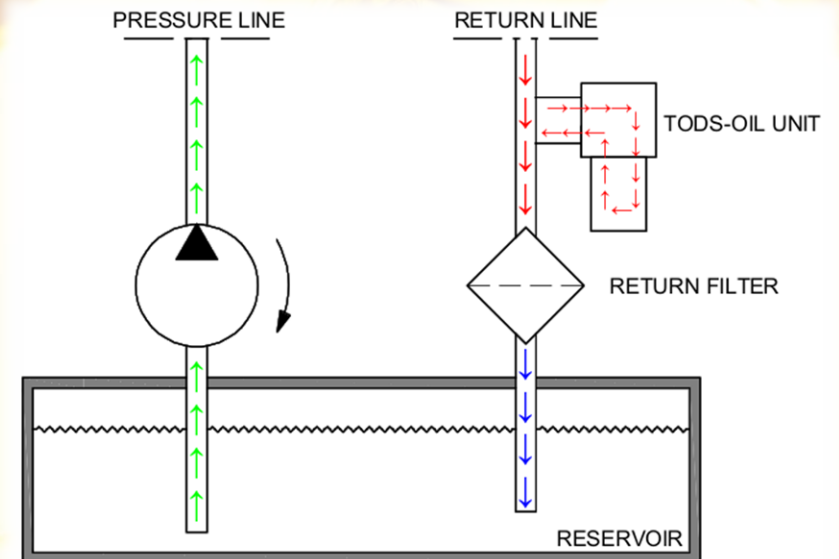

Applications
TODS - Fits Everything Everywhere



Tribo Oil Dock System
Get In Touch
Email: sales@tods.com



- Engine Oil
- Differential Oil
- Transmission Oil
- Hydraulic Steering Oil
- Hoist and Brake Oil
- Coolant
- ...

